

# Big Data from Pipeline Simulation

Presenter

Jonathan Theakston

Simulation Software Limited

# Pipeline and Equipment Data Storage



Pipeline data will be stored within a GIS database incorporating all physical data

Pipe geometric co-ordinates, lengths, diameters, wall thicknesses, elevation profiles, material type, condition

Equipment characteristics e.g. pump and valve operating curves, sizes, valve closure rates, pump inertias, tank shapes, power sources and tariffs

Most pipeline simulators will be configured from the same GIS information automatically.

# Pipeline Simulation Capability

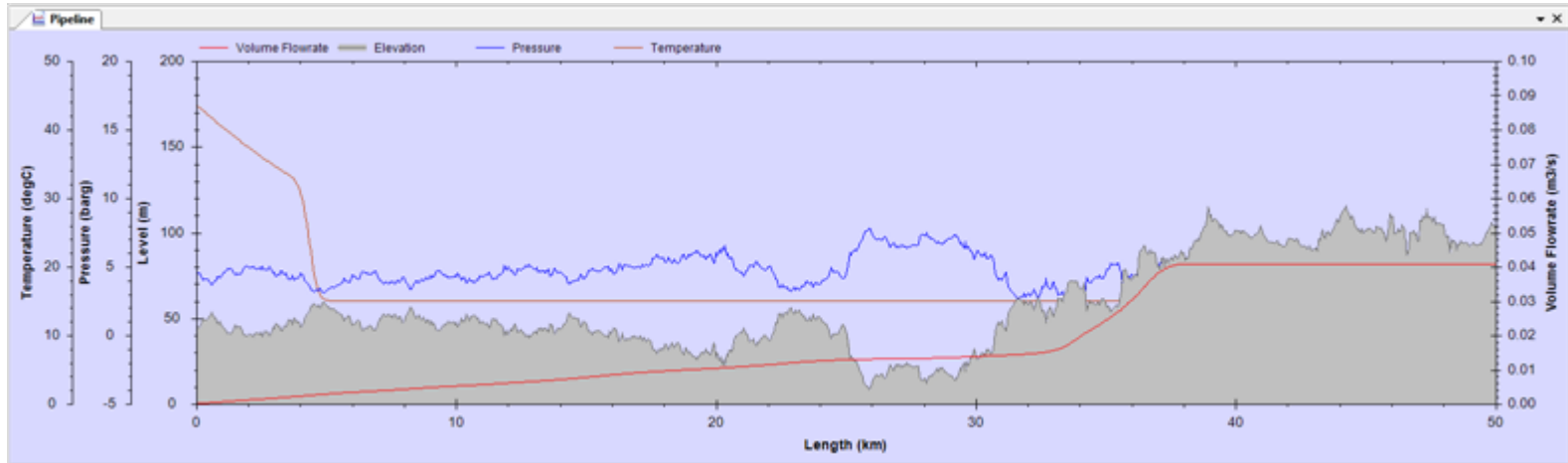

The simulators will match reality. They will be fully transient using very short timesteps and have the ability to automatically accelerate at the expense of accuracy.

They will be able to simulate

- a) Flow
- b) Pressure
- c) Temperature
- d) Variable product properties including virtual properties such as age and source and components such as chlorine or fluoride.

They will include detailed control schemes including those that are administered by SCADA systems and local RTUs

# Big Data from Pipeline Simulation in Real Time

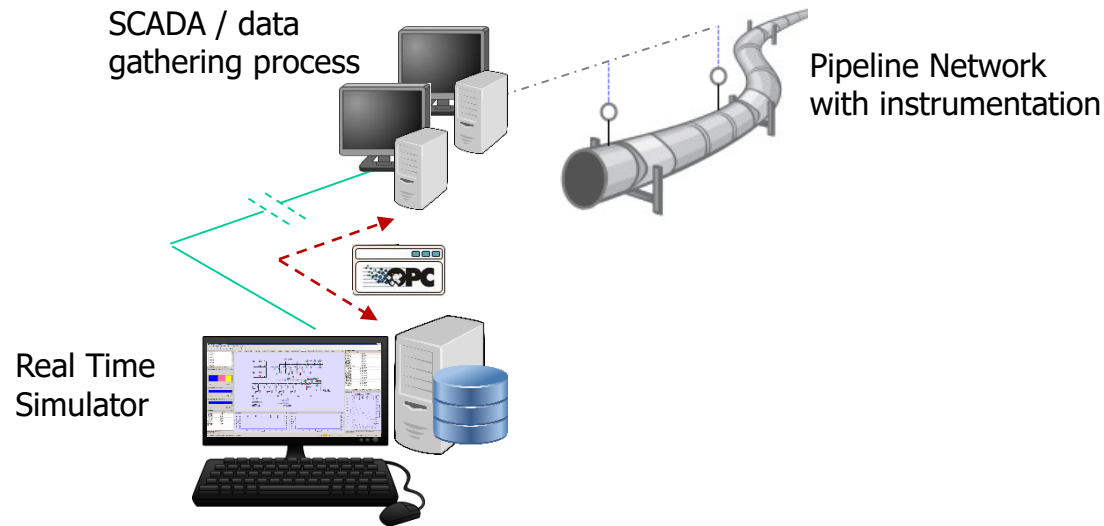

More measurements will be added to pipelines. Data updated several times a second will be telemetered and recorded in centralised databases.

Measurements will drive simulation models in real time to provide information on the entire pipeline / network where measurements do not exist.

This explodes the amount of real-time data available.

1. All pressures, flows, temperatures.
2. Tracking data including contaminants, additives, water source and age.
3. Equipment operating parameters.

All simulated data recorded on a cyclical basis (seconds/minutes) and stored in a centralised database creating very large data sets.



# Big Data from Pipeline Simulation in Real Time

With the arrival of SMART metering, measurements will be available at all consumer consumption points allowing networks to distribution level to be simulated in real time.

All pipeline configurations will then be able to be simulated from simple trunk mains to distribution networks and district heating systems.

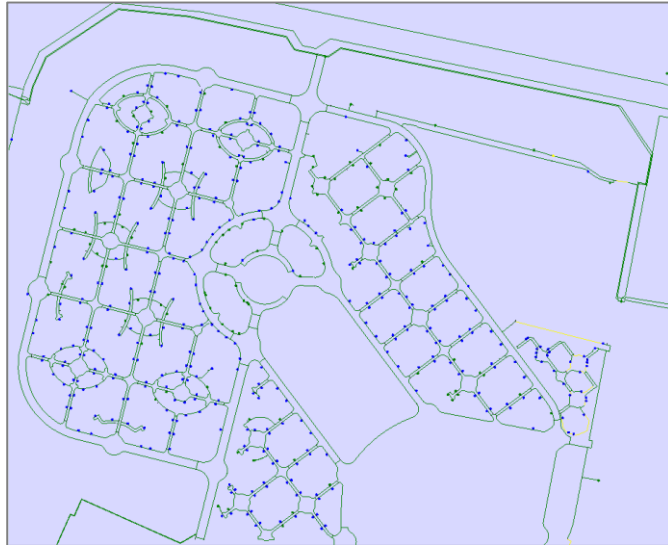

Consumer Distribution

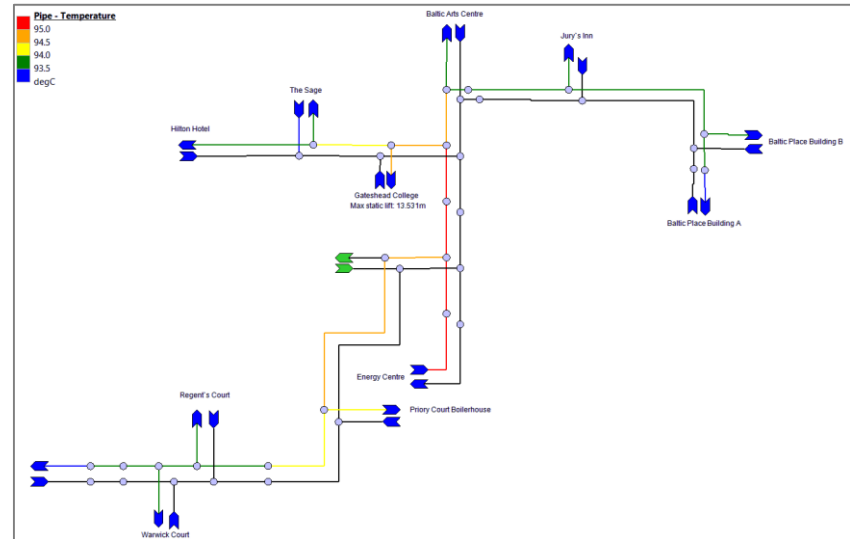

District Heating

# What are we going to do with all this data

The current status of the network for any property will be viewed in real time though coloured schematics and route based profiles.

Calculations will be able to be displayed alongside any other GIS data.

Heat maps will be used to identify current operating anomalies on the system. This requires distributed measurement for comparison with simulated data.

Installation of a real time model will help water companies understand the true nature of their systems and help to recover any lost information and understanding.

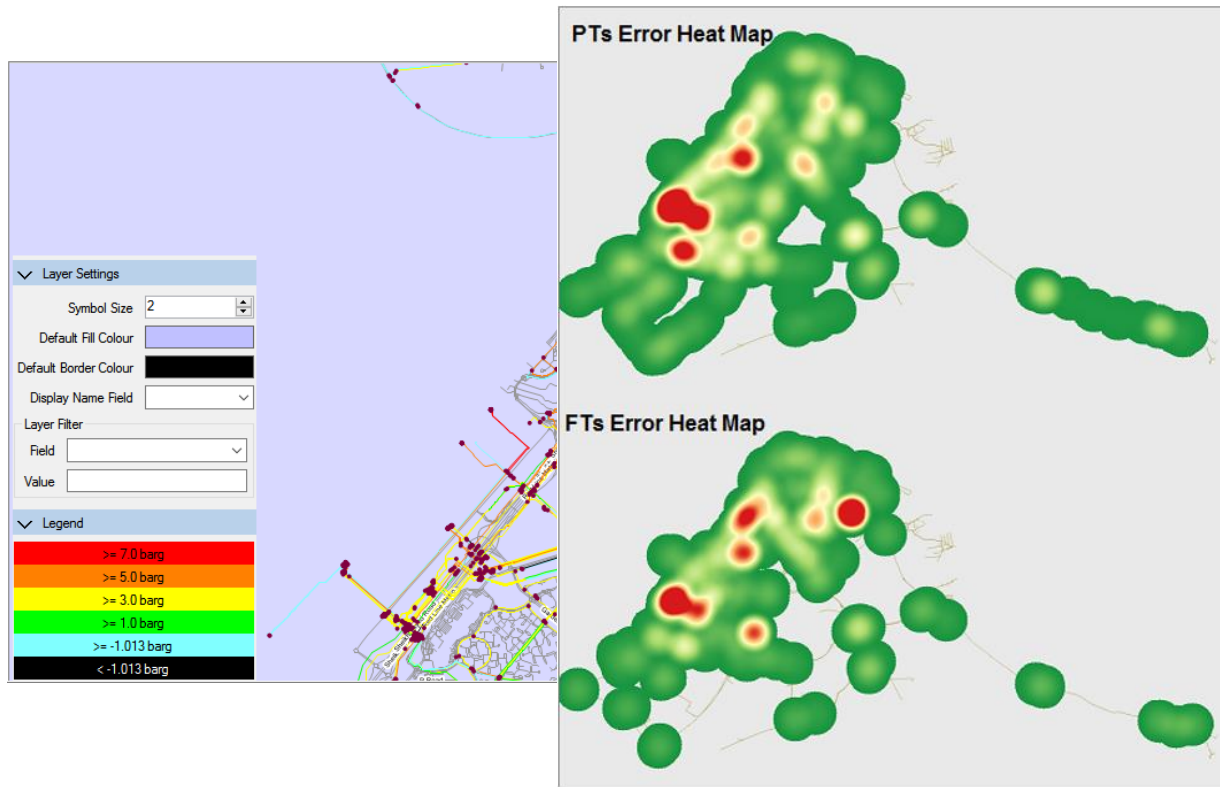

# What are we going to do with all this data

Applications will analyse the real time data to provide a range of functions.

1. Burst Detection and Location
2. Background leakage calculations
3. Water Balancing
4. Over pressure reporting
5. Efficiency Analysis
6. Age, quality and source analysis
7. Optimisation

Prediction of future conditions based on planned operations and consumer demand expectations.

What-if and Surge Analysis using current conditions

Training Simulation at an engineering or SCADA level

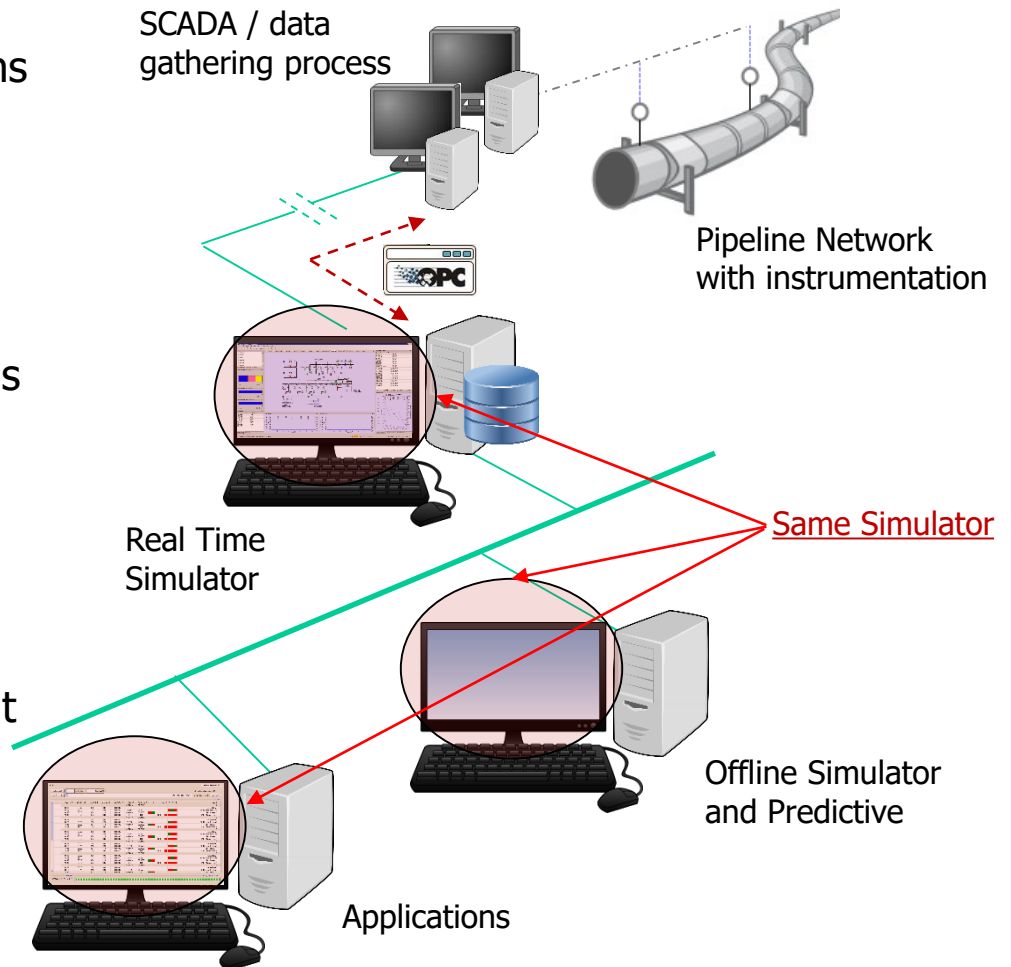

This is what could be termed a **SMART NETWORK**

# Advancements in Pipeline Simulation

The simulators will change from executables to services and will run server based or cloud based.

Solvers will use parallel processing for substantial increase in speed.

The GUI's (graphical user interfaces) will become remote clients allowing the simulators and their data to be accessed via web displays, remote interfaces and mobile applications.



Alternative GUI's will be provided, allowing users to visualise layout and simulator output in a 3 Dimensional format.

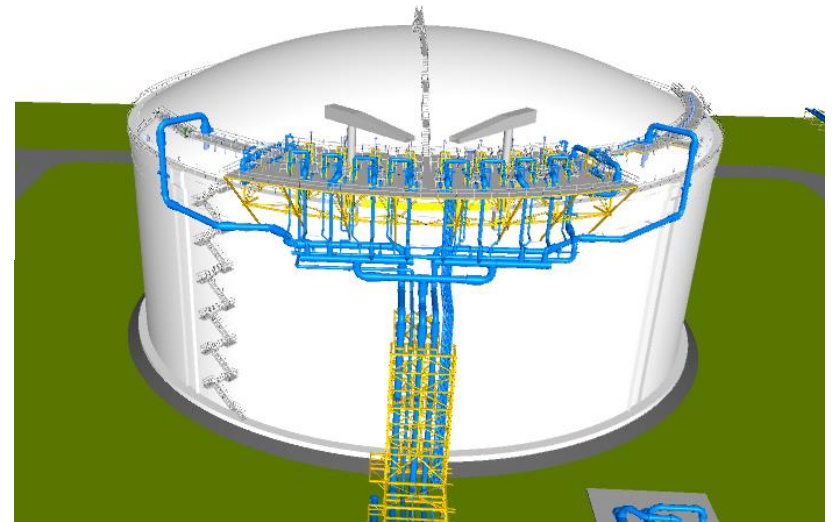



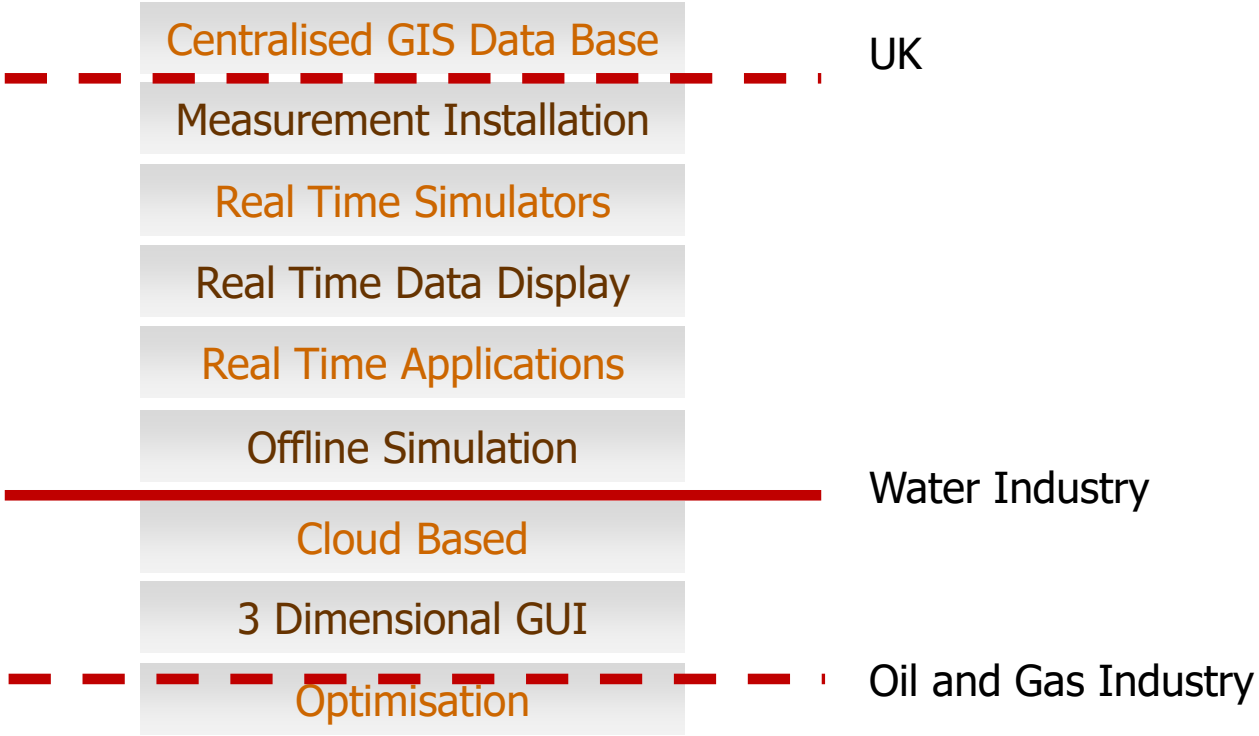

## Where Next

# Twenty65

The industry already has very good solutions for the transient simulation of pressure, flow, temperature models and varying product properties.

They are based on principals developed in the late 60's and ongoing feedback from real time installations. **We have to be very careful not to lose this knowledge.**

$$\frac{1}{\sqrt{f}} = -4 \log_{10} \left( \frac{k_s}{3.71d} + \frac{1.26}{\text{Re} \sqrt{f}} \right)$$

$$\frac{dh}{dx} + \frac{v}{g} \frac{dv}{dx} + \frac{1}{g} \cdot \frac{dv}{dt} + \frac{2fv^2}{gd} = 0$$

Through continuing research, models will be developed for other physical attributes such as :-

- Sedimentation
- Corrosion
- Bacterial build up
- Additives
- Air models including entrained and un-primed pipework.

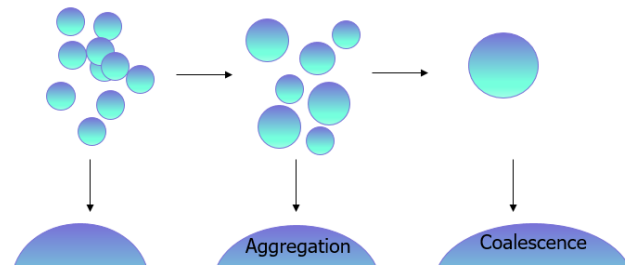

With faster solvers, optimisation of networks according to a defined objective will become feasible

# Twenty65

There will be close integration with other simulation packages to link associated utilities and influencing factors.

- Transient Open Channel Simulation (culverts, storm tunnels, sewerage systems)
- River Simulation and Terrain Run-off simulation
- Weather Simulation for predicting storm durations
- Electricity simulators
- Neural Net models for predicting water requirements based on weather forecasts, calendar and user types.



# Twenty65

- Remote cloud based applications will allow users to test operations before they are undertaken based on current conditions
- Virtual Pipeline Overlays will allow engineers to view current operating conditions and locate anomalies

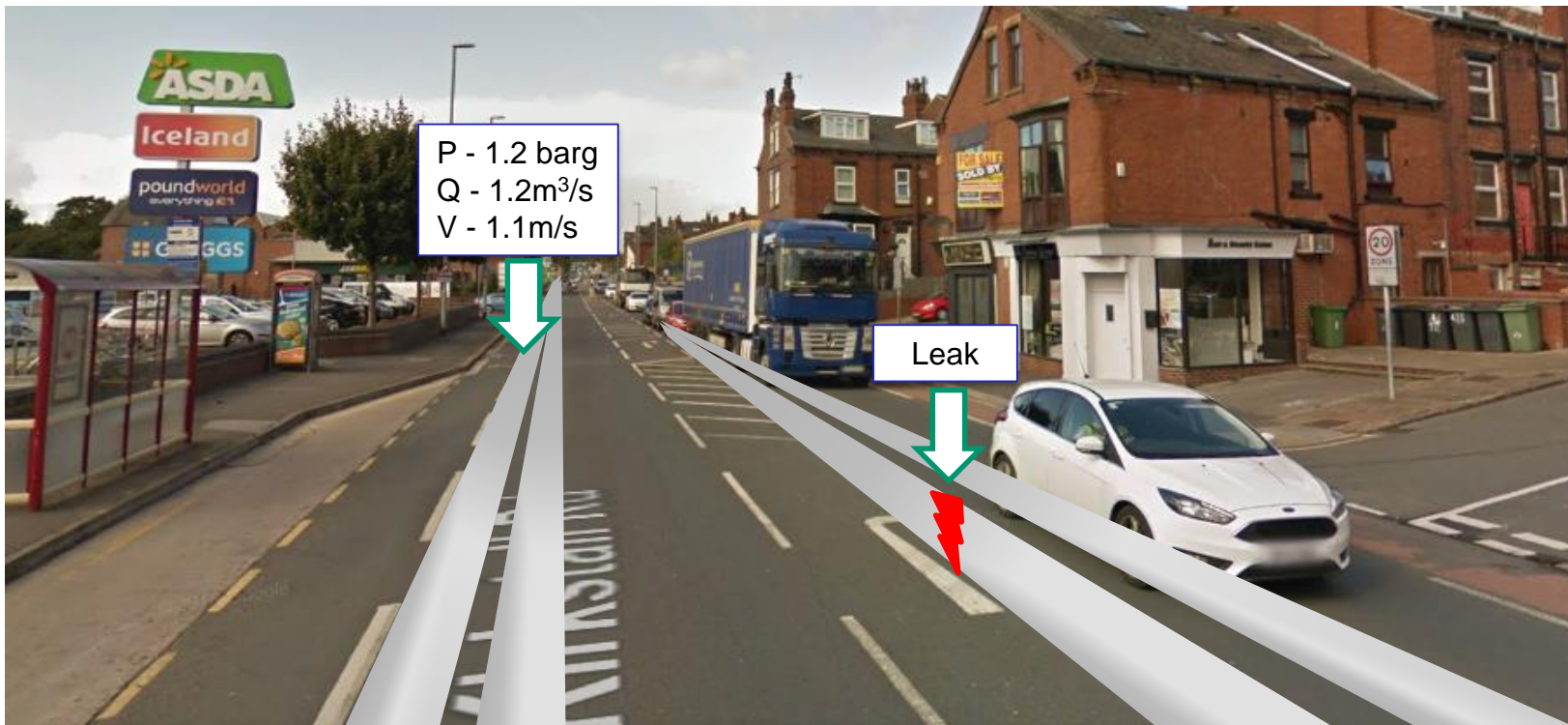

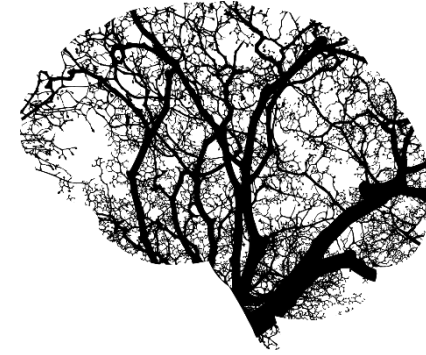

The storage of large amounts of measured and reliable simulated data opens the door for artificial intelligence.

Using pattern recognition and neural net based learning algorithms, AI will be able to analyse the stored data to :-

- Ensure the security of supply through optimised distribution of water.
- Prevent potentially hazardous operations through recognition of previous anomalies.
- Leakage detection and location using neural networks trained by simulated data.

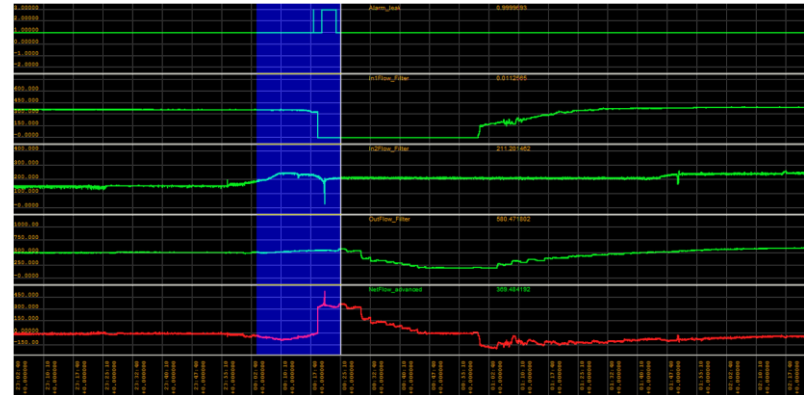

We will most likely need to learn to trust AI and use it in an advisory capacity first !

Or perhaps pipeline simulation will lose its emphasis if we move to the localised harvesting of water.

